

Dill[®] 1504-572

TPMS Trailer Kit

Key Features:

- Visual and audible warnings
- Set desired PSI level
- Mounts to windshield or dashboard
- Alerts when tire pressure is too high
- Alerts when tire temperature is too high
- Easy Plug-In DC power source
- Adjustable Angle Valve Stems
- Alerts when tire pressure is too low



For more information visit our website at <http://www.trailertpms.com>

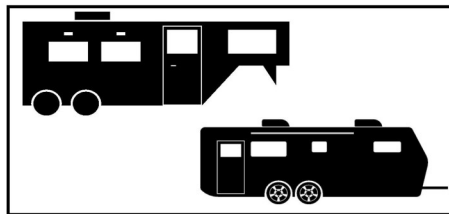
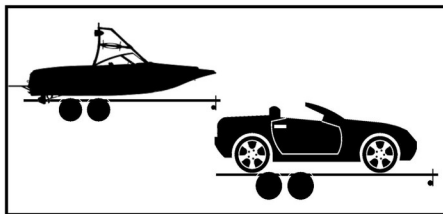

Thank you for purchasing the Dill TPMS Trailer Kit. Properly inflated tires increase fuel economy, reduce tire wear, and increase handling. A warning system to notify you of an underinflated tire will help give you time to respond prior to potentially damaging your tire or trailer.

Table of Content	Page
1. System Overview:	3
1.1 System Components	3
1.2 How the System Works	3
1.3 Display indicators and Controls	4
1.4 Transmitter Components	4
1.5 Position of Transmitter and ID Module	5
3. Transmitter Installation:	5-7
3. Using TPMS Unit:	7
3.1 Getting Started	7-8
3.2 Transmitter Activation	8
3.3 Cold Inflation Pressure Setting	8
3.4 Restore Default Setting	8
3.5 Normal Monitoring	9
3.6 Warnings	9-10
3.7 Tire Rotation	10-11
3.8 Replace Transmitter and ID Module	11
3.9 Restart System	11
4. Specifications:	12
4.1 Transmitter	12
4.2 Display Unit	12
4.3 Component Part Numbers	12

1. System Overview

As a vehicle safety device, the TPMS trailer kit monitors tire pressure and temperature. It will provide warnings about abnormal conditions such as low pressure, high pressure, and high temperature.

1.1 System Components

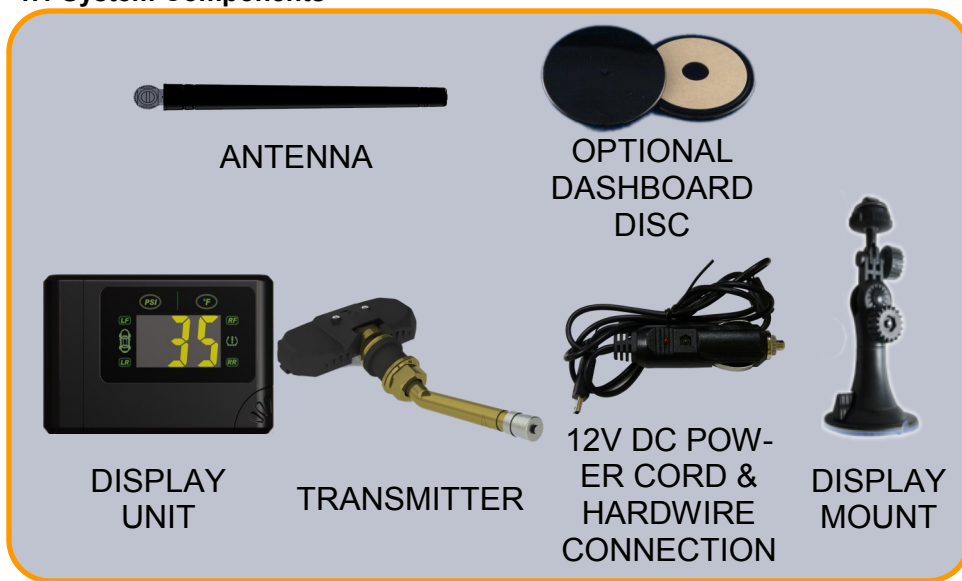

1.2 How the System Works

A transmitter is installed in each wheel with a brass valve stem and monitors the pressure and temperature conditions inside each wheel of the vehicle. This data is wirelessly sent to the receiver that is installed on the vehicle. The receiver displays the pressure and temperature for each tire position. When an abnormal condition is detected, the display will alert the driver.

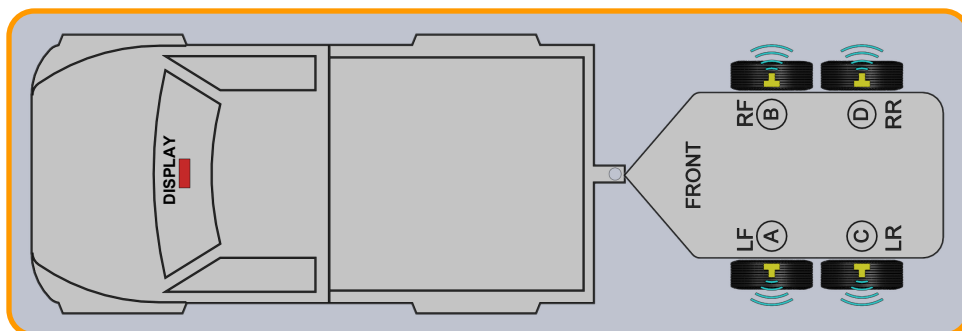

1.3 Display Indicators and Controls

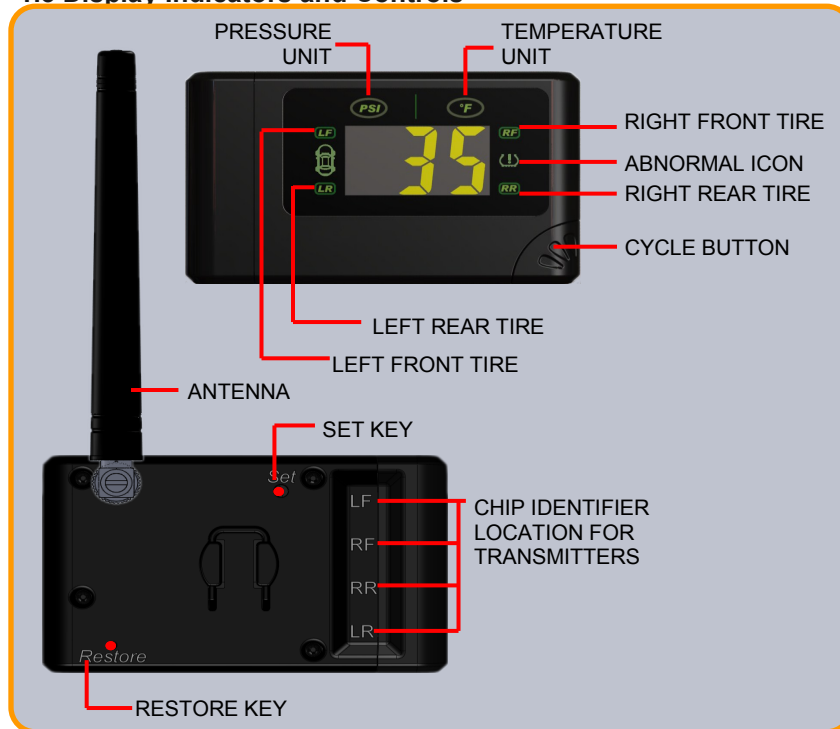

1.4 Transmitter Components

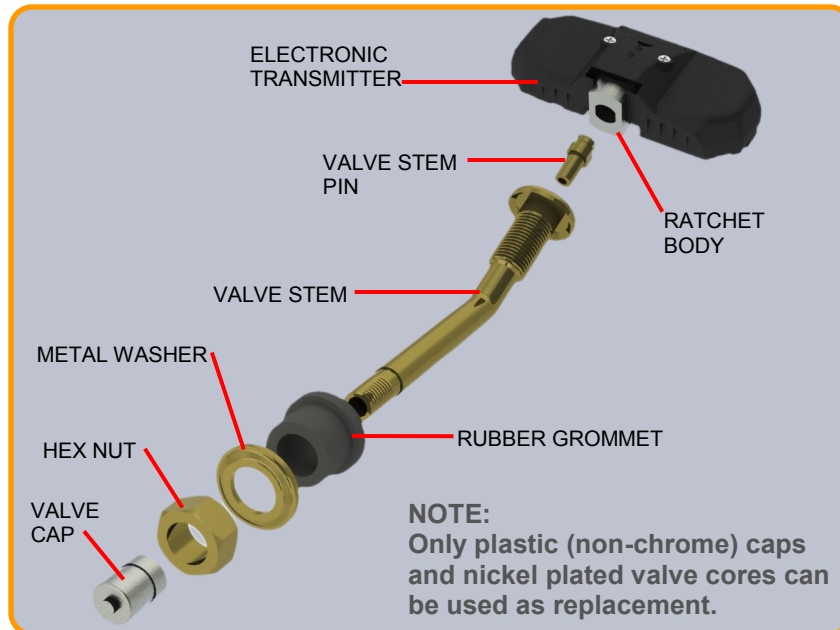

1.5 Position of Transmitter and ID module

Note the default installation position of the transmitter and ID modules as illustrated. A letter identifier marked on the transmitter, id module, and hex nut is shown on each component.

The letters “LF/RF/LR/RR” on the back of the display unit correspond to the tires’ respective positions. Each pair of transmitter and ID module need to be installed in the same position.

To access the ID modules, pull the removable cover away from the display unit.

For example, if you install transmitter “A” in the left front tire, then you should plug the ID module “A” in “LF” position on the receiver.

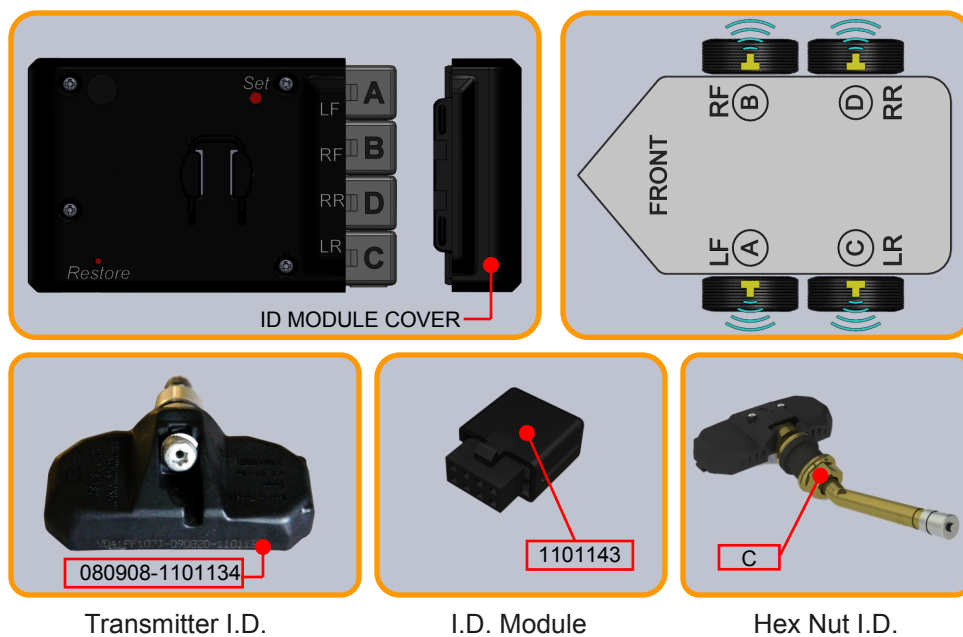

If you purchased a 2 tire system for your trailer, verify that the installation of your transmitter and ID modules are in their proper locations.

Note the matching of the transmitter and hex nut when mounting the ID module. When a tire rotation or transmitter replacement occur, rotate or replace the corresponding ID module simultaneously. Refer to 3.7

2.0 Transmitter Installation

Before installation into the rim hole, you must assemble the transmitter and valve stem together.

2.1 Unscrew the hex nut and remove the metal washer from the valve stem.

2.2 Install the valve stem assembly via ratchet body into the transmitter. Slide the body into the transmitter. Verify the teeth from the ratchet body is opposite from the transmitter teeth.

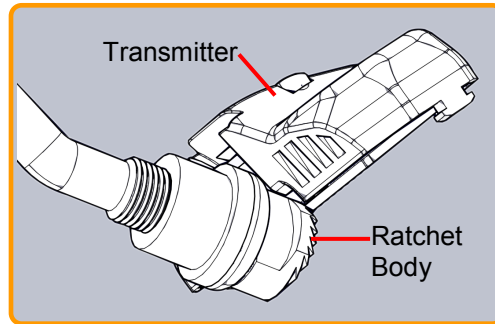

2.3 Insert the valve stem through the rim hole and verify that the rubber grommet is seated against the rim hole surface.

2.4 Adjust the angle of the transmitter body and verify the transmitter is resting flat against the wheel rim surface.

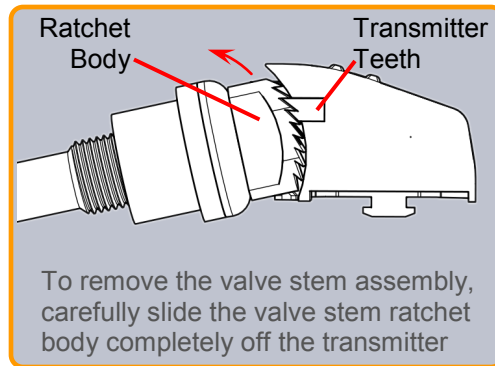

2.5 Verify 3 conditions when installing the transmitter assembly onto the wheel rim:

2.5.1 At least one of the transmitter's feet always contacts the rim surface.

2.5.2 The grommet is fully seated against the valve hole.

2.5.3 From the outside of the wheel, the valve stem is perpendicular to the rim's valve hole.

2.6 Place the metal washer and hex nut on the valve stem and turn the hex nut clockwise until the rubber grommet is pressed against the wheel rim surface.

2.7 Tighten the hex nut 35 to 40 inch pounds of torque to secure the valve stem to the rim. Verify at least one of the transmitter's feet has direct contact on the wheel rim surface. If not, uninstall the transmitter and redo it from 2.5.

2.8 Lock the wheel rim on the tire changer. Apply lubricant on both tire beads and rim. Mount the lower tire bead on the rim. Ensure that the tire bead does not touch the electronic module during mounting.

2.9 Mount the upper tire bead the same way and inflate the tire to standard cold inflation

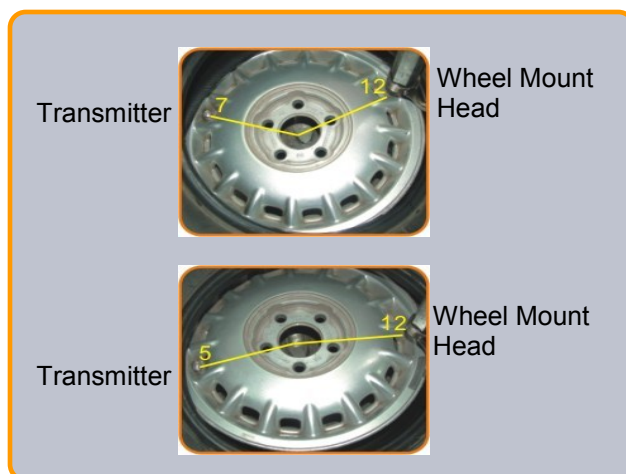

2.10 Apply suds on the valve tip, grommet / rim seal. If no leakage is found, install the valve cap. Otherwise, re-inspect and resolve leak issue.



2.11 Dynamically balance the wheel before it is put back on the vehicle.



2.12 Use the same procedures to install the other three sensors. Install A, B, C, and D transmitter on the Left Front wheel (LF), Right Front wheel (RF), Left Rear wheel (LR) and Right Rear wheel (RR) respectively.

2.13 Visually inspect the wheel rim, valve stem, and electronic module to ensure no damage has occurred. Pressurized the tires to your desired cold

3. Using TPMS Unit

3.1 Getting Started

3.1.1 Install the supplied antenna to your display unit located at the back of the unit.

3.1.2 Use the display mount to affix the display unit on the windshield or dashboard. Do not block the driver's view. Adjust the viewing angle of the display, if necessary.

3.1.2 Plug the power cord into the display unit and plug the adapter into auxiliary power supply.



An immediate audible “Beep” sound will indicate the display unit is on. In 2 to 3 minutes, the display unit will show the tire pressures in yellow, along with four blue tire position lights.

3.2 Transmitter Activation

Note: reference section 2 for transmitter installation.

The transmitters are shipped in “sleep” mode for battery conservation and will be activated when the transmitter detects pressure in the tires or when the vehicle speed exceeds 20mph.

The default cold inflation pressure setting of the display unit is 35PSI. The display unit is programmed to provide a low pressure warning when the pressure is 20% lower (28PSI) and 30% higher (46PSI).

Cold inflation pressure can be set to your desired pressure and a warning will alarm at 20% below and 30% above this pressure. For example, the driver will be alerted at the following low and high pressures base on various set pressure:

PSI LEVEL	20% LOWER	30% HIGHER
35	28	46
50	40	52
80	64	104

3.3 Cold Inflation Pressure Setting

Cold inflation pressure setting is pre-set at the to 35PSI, when installation and replacement of each transmitter and ID modules.

To change cold inflation pressure setting, perform the following:

- 3.3.1 Inflate the tire pressures to the recommended cold inflation pressure.
- 3.3.2 Press the “SET” key on the back of display and hold for 8 seconds to enter new cold inflation pressure setting. A ‘beep’ will sound and all indicator lights will turn off and the screen display will show “ddd”. Allow 3 to 5 minutes for the receiver to accept new cold inflation pressure setting.
- 3.3.3 To check a tire’s cold inflation pressure setting, press and release the “Cycle Button” twice. Repeating this step will cycle through each tire’s pressure setting.

3.4 Restore Default Setting

To switch to default setting, press and hold the “RESTORE” key for 3 seconds. The display unit will switch back to default operations within 30 seconds.

3.5 Normal Monitoring

3.5.1 Stationary State:

The transmitter will detect tire pressures and temperatures at 8-second intervals and transmit the data to the display at 2-minute intervals as long as they are normal. As the data is received, the display will refresh.

3.5.2 Moving State:

The inertial switch of transmitter is on when the speed exceeds 16mph.

The transmitter will detect tire pressures and temperatures at 4-second intervals and transmit the data to the display at 30-second intervals as long as they are normal. As the data is received, the display will refresh.

3.5.3 Normal Data Display:

The display will automatically circulate among the tire positions in the following order LF/RF/RR/LR.

Press and release the "Cycle Button" to view the tire temperatures.

3.6 Warnings

3.6.1 Low Pressure Warning

If the current pressure in a tire is 28PSI or lower in default mode or 20% lower than the cold inflation pressure setting, then the following will occur:

1. The display will show the pressure of the abnormal tire and the digits will flash.
2. An audible alert warning sound will be heard.
3. The abnormal icon will become red.
4. The indicator for the abnormal tire will become red.

The system will not return to normal monitoring until the problem(s) is corrected.

3.6.2 High Pressure Warning

When current pressure in a tire is 46PSI or higher in default mode or 30% higher than the cold inflation pressure setting, then the following will occur:

1. The display will show the pressure of the abnormal tire and the digits will flash.
2. An audible alert warning sound will be heard.
3. The abnormal icon will become red.
4. The indicator for the abnormal tire will become red.

The system will not return to normal monitoring until the problem(s) is corrected.

3.6.3 High Temperature Warning

When the current temperature in a tire exceeds 176°F, the following will occur:

1. The display will show the temperature of the abnormal tire and the digits will flash.
2. An audible alert warning sound will be heard.
3. The abnormal icon will become red.
4. The indicator for the abnormal tire will become red.

The system will not return to normal monitoring until the problem(s) is corrected.

3.6.4 System Malfunction

If the display is not receiving the signals from a transmitter(s), in the tires, the display screen will appear as dashed lines “---” .

If you are not receiving a signal from the transmitter(s), verify the following conditions .

1. Verify that the unit is plugged into the DC power supply. Power off the display unit and restart the system. The system will return to normal monitoring after properly receiving signals from the transmitter(s).
2. Verify that the ID module chip(s) are installed properly in the correct locations of the display unit.
3. Check your antenna connection.
4. Drive your vehicle over 20mph for 3 to 5 minutes. This will “wake” the transmitter and begin to transmit a signal to your display unit.

If the display unit is working properly and it still does not receive a signal from the transmitter(s), then the transmitter(s) and id module(s) must be replaced simultaneously.

A replacement transmitter and id module can be purchased from a Dill distributor or retailer, list available at www.trailertpms.com.

Note: When requesting a replacement of the damaged transmitter, order the same letter identifier (reference 1.5).

3.7 Tire Rotation

3.7.1 Reference your tire manufacturer for proper tire rotation on your trailer.

3.7.2 Note the current installation positions of the transmitter and ID modules.

For example, if you need to rotate the Left Front Wheel (LF) transmitter A and Right Rear Wheel (RR) transmitter C, then

Interchange ID chip module A and ID chip module C.

Reactivate the system (reference section 3.2) to accept new transmitter positions and to indicate the proper location of the transmitter on the display unit.

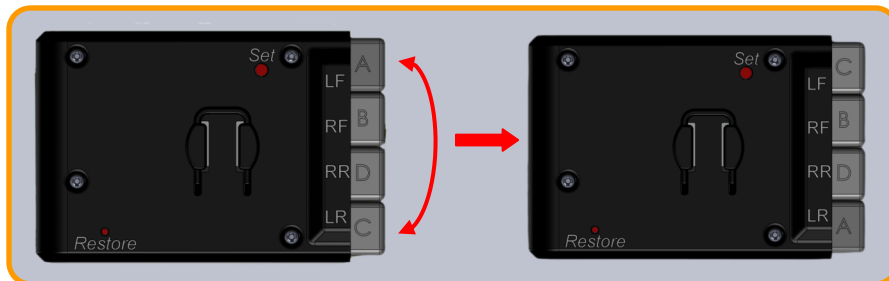

3.8 Replacement of Transmitter and ID Module

Verify a “System Malfunction (reference section 3.6.4)” before replacing the transmitter or ID module.

3.8.1 Replace the inoperable transmitter and ID module with a new one.

3.8.2 Transmitter Activation (reference section 3.2).

3.8.3 Reset the cold inflation pressure setting (reference section 3.3).

3.9 Restart the system

The system has to be restarted to re-identify the ID module in the following situations:

3.9.1 Tire rotation.

3.9.2 Replacement of a transmitter and ID module.

3.9.3 To restart the system, disconnect the power cord for 1 minute and plug in again.

4. Specifications

4.1 Transmitter

- Weight: 1.25 oz. (35g)
- Dimensions: 0.59" x 2.50" x 1.11" (1.5 x 2.8 x 6.4 cm)
- Operating Temperature Range: -40°F to 257°F (-40°C to 125°C)
- Pressure Accuracy: ±2PSI (±.14Bar)
- Temperature Accuracy: ±5.4°F (±3°C)
- Battery life: 5 to 7 years
- Maximum Sensing Pressure: 188PSI (12.96Bar / 1296Kpa)
- Maximum Cold Inflation Pressure: 108PSI (7.5Bar / 750Kpa)
- Frequency: 433.92MHz

4.2 Display

- Power Consumption: 130mW (regular) / 230mW(Max)
- Power Supply: DC12 Volt
- Weight: 1.06oz. (30g)
- Dimensions: 3.35" x 1.97" x 0.79" (8.5 x 5 x 2 cm)
- Pressure resolution: 0.1PSI (.01Bar / 1Kpa)
- Temperature resolution: 2°F (1°C)

4.3 Component Part Numbers

PART NUMBER	DESCRIPTION
1504-2	TPMS DISPLAY UNIT
1504-3	DISPLAY MOUNT
1504-4	TPMS DC POWER CORD
1504-6	INSTRUCTIONAL MANUAL
1504-7	TPMS HARDWIRE POWER CORD
9300-A	TPMS TRANSMITTER ASSEMBLY "A"
9300-B	TPMS TRANSMITTER ASSEMBLY "B"
9300-C	TPMS TRANSMITTER ASSEMBLY "C"
9300-D	TPMS TRANSMITTER ASSEMBLY "D"